

NOTES:

- 1 TOLERANCES UNLESS OTHERWISE SPECIFIED: $\pm 0,15$.
- 2 MODULAR JACK P.N. 216446-1, 216446-2, 3-216446-1 AND 3-216446-2 ARE DELIVERED WITH PLASTIC SOLDER STOP INSTALLED, TO PREVENT SOLDER ENTERING THE JACK. REMOVE SOLDER STOP AFTER SOLDERING.
- 3 FOR PERFORMANCE REQUIREMENTS SEE AMP PRODUCT SPECIFICATION 108-19064.
- 4 FOR APPLICATION REQUIREMENTS SEE AMP APPLICATION SPECIFICATION 114-19019.
- 5 MOLDED-IN CHARACTER "1,6" MEANS FOR 1,6mm PRINT THICKNESS.
- 6 FOR PACKAGING SEE SHEET 2.
- 7 PREFERRED DIRECTION FOR STAMPING OF HOLE TO OBTAIN A BROKEN EDGE AT JACK ENTRY SIDE.
- 8 TRUE POSITIONING OF THE SOLDER TINES MAY BE AFFECTED BY BULK PACKAGING. THE SOLDER STOP COULD BE LOOSENED DURING TRANSPORT.

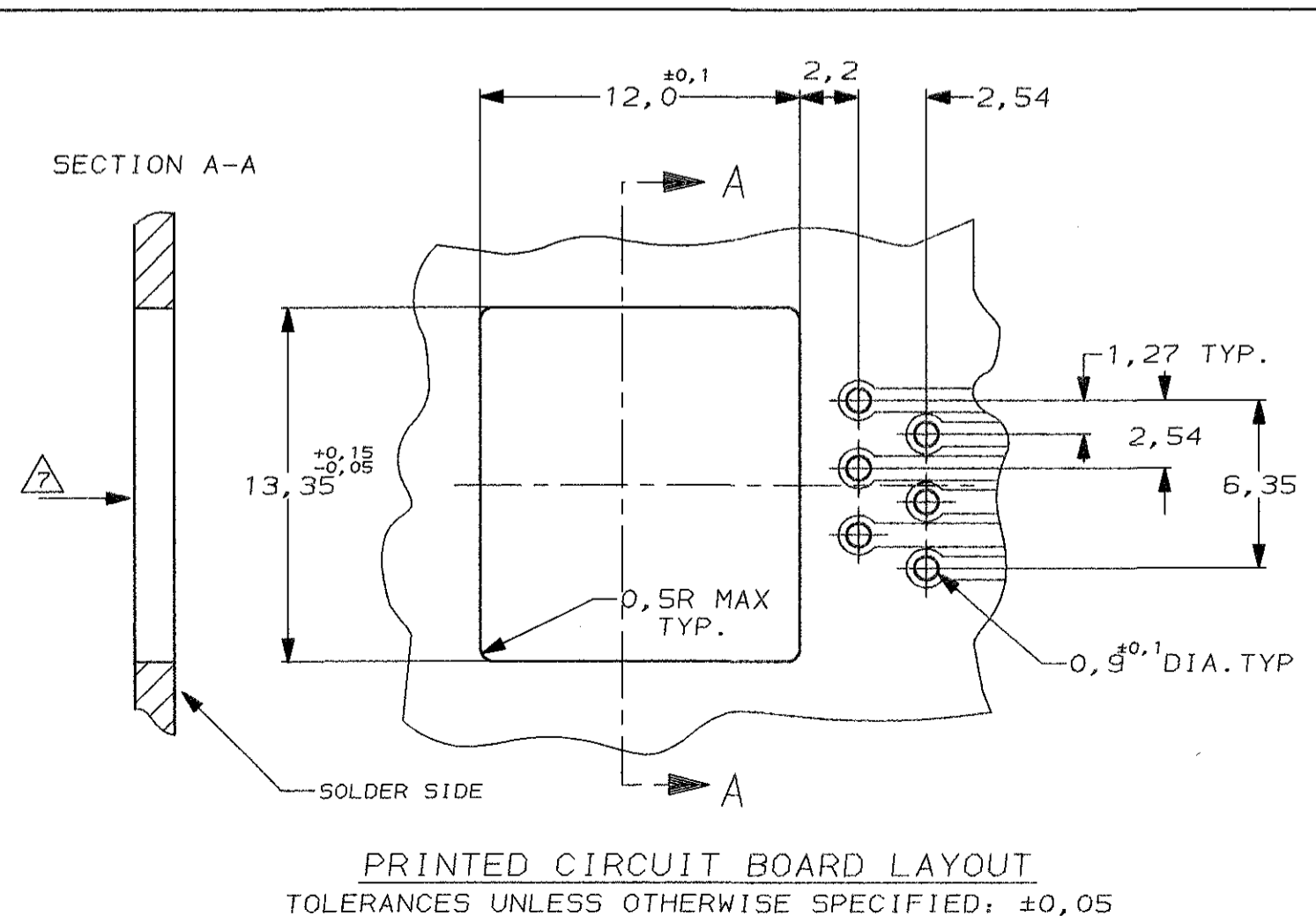
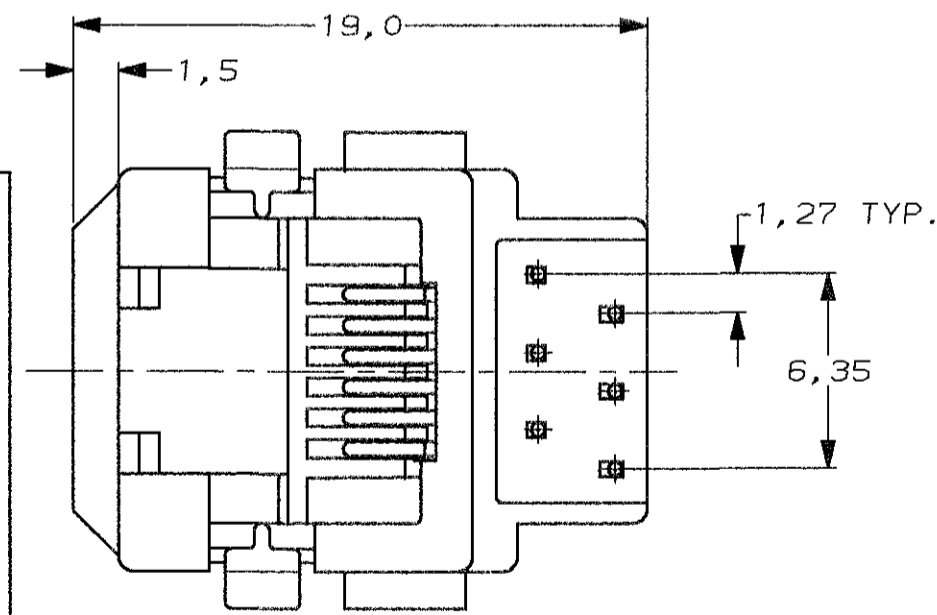
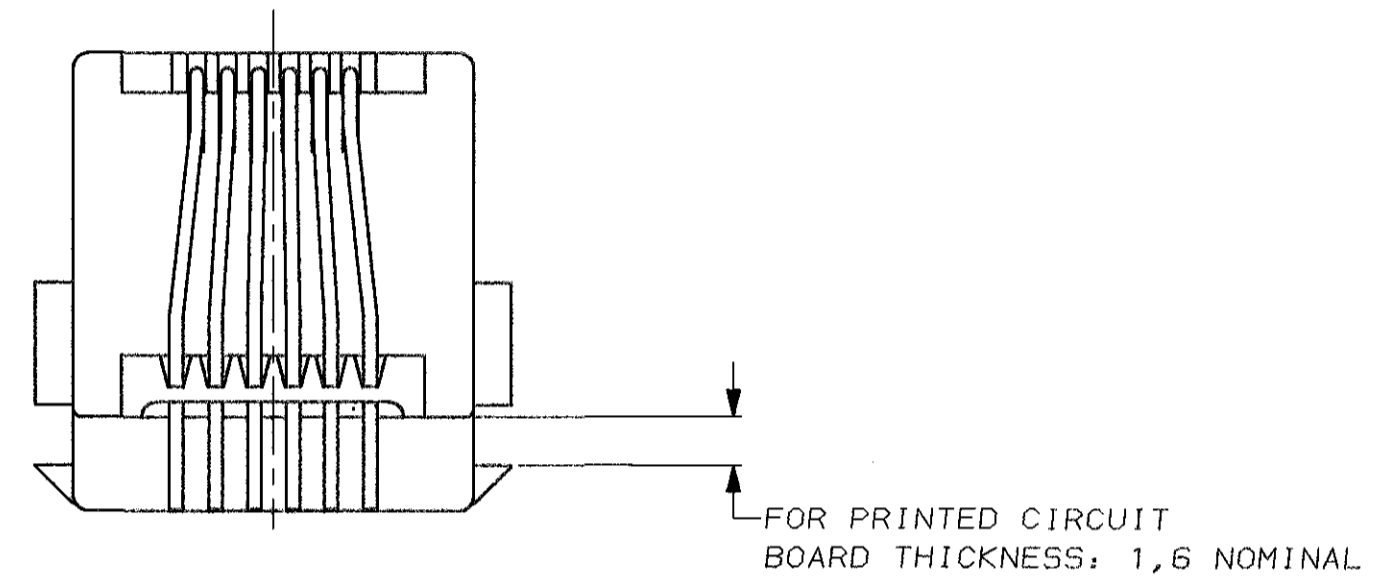
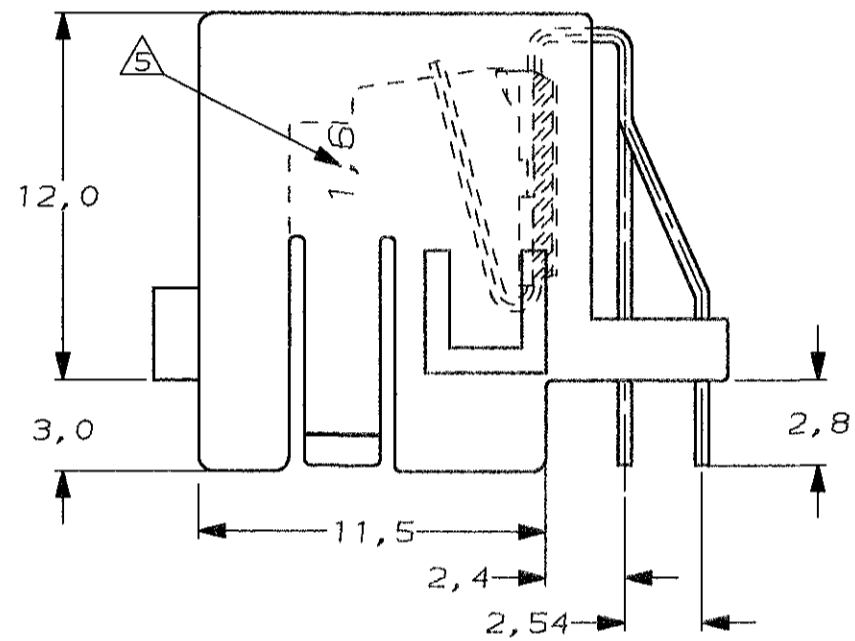
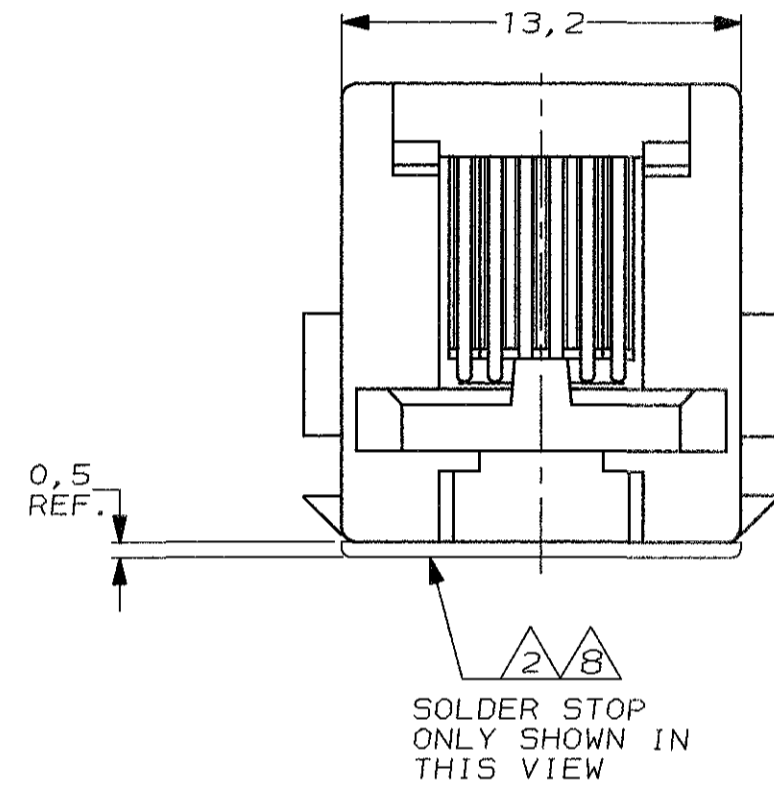
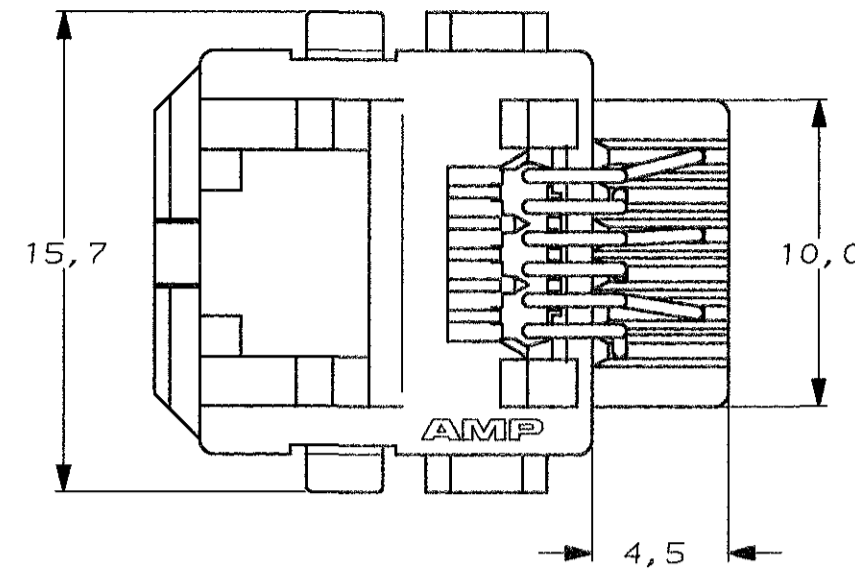

DESCRIPTION	FINISH	MATERIAL	PARTNUMBER
6 POS./4 CONTACTS WITH SOLDER STOP	1,25µm MIN. GOLD OVER	20X 6.F. NYLON	3-216446-2
6 POS./6 CONTACTS WITH SOLDER STOP	1,25µm MIN. NICKEL IN CONTACT AREA	COLOR: BLACK UL 94-HB	3-216446-1
6 POS./4 CONTACTS WITH SOLDER STOP	2,0µm MIN. TIN LEAD OVER 1,25µm MIN.	CONTACTS: PHOS. BRONZE	216446-2
6 POS./6 CONTACTS WITH SOLDER STOP	NICKEL ON SOLDER TINES.		216446-1

DR.	DATE	CHK.	DATE	APP.	DATE	DWG. No.	REV. LTR.	SHEET
M.v.ESSEN	29 NOV'95	W.BRUMMANS	-	C.v.TILBURG	-	C-216446	R	1 OF 2

REVISION RECORD	DR.	CHK.	DATE
R	EVE	WB	14 SEP 96
P	EVE	WB	25 MRT 97
N	EVE	WB	23 JAN 97
M	EVE	WB	18 DEC '96
L	EVE	WB	22 OKT 96
K	MVE	WB	25 JUN '96

CUSTOMER DRAWING		FOR REFERENCE ONLY WILL NOT BE UPDATED	
© COPYRIGHT 19- BY AMP HOLLAND B.V.			
ALL INTERNATIONAL RIGHTS RESERVED. AMP PRODUCTS MAY BE COVERED BY U.S. AND FOREIGN AND/OR PATENTS PENDING.			
THIS DRAWING IS UNPUBLISHED RELEASED FOR PUBLICATION			
AMP HOLLAND B.V. 's-Hertogenbosch, The Netherlands.		NAME	
MODULAR JACK, 6 POS., BOTTOM ENTRY VERSION FOR PRINTED CIRCUIT BOARD MOUNTING			

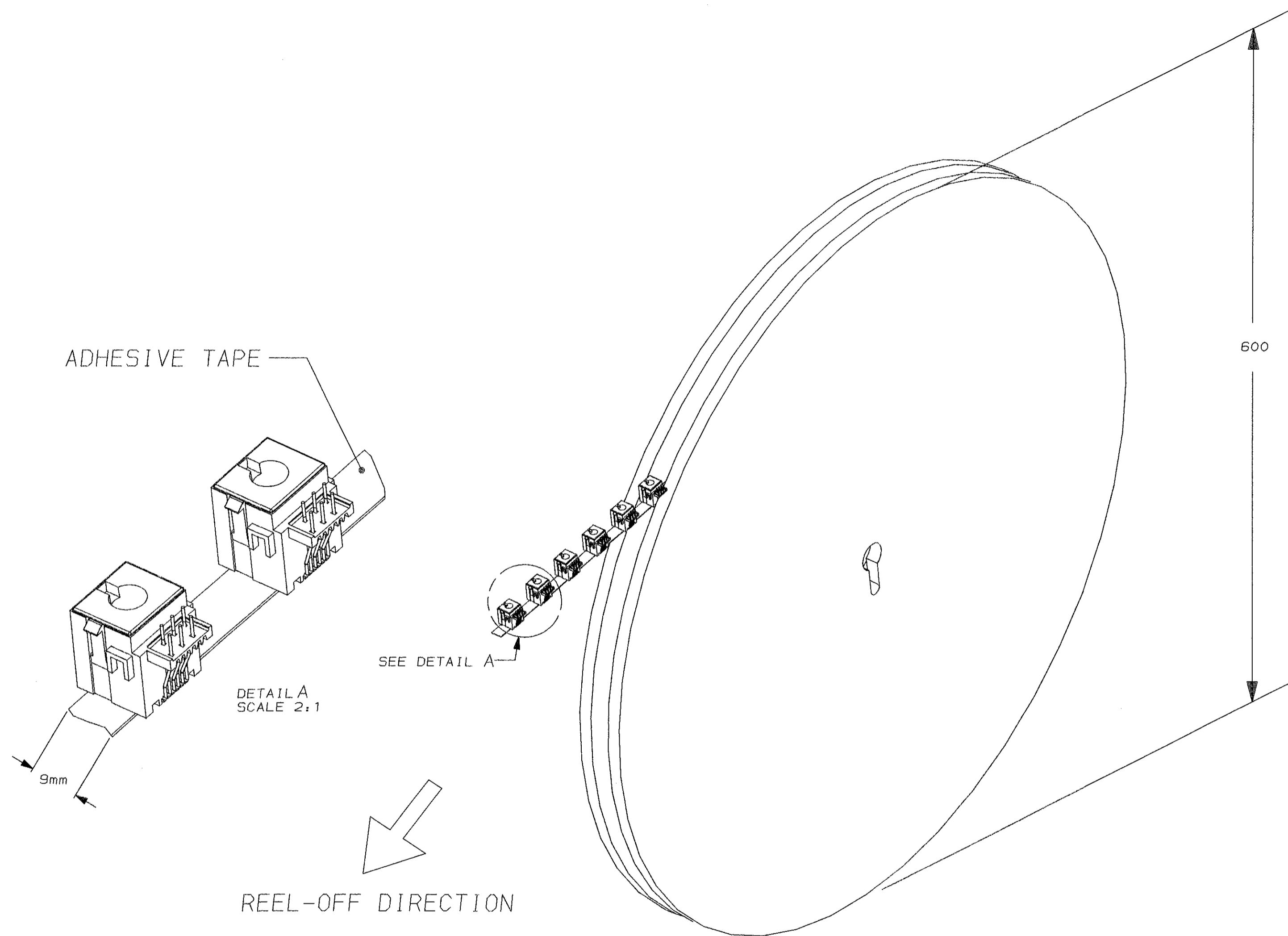

			FINISH		MATERIAL		PARTNUMBER		
-	-	-	-	-	-	-	CUSTOMER DRAWING FOR REFERENCE ONLY WILL NOT BE UPDATED		
-	-	-	-	-	-	-	© COPYRIGHT 19- BY AMP HOLLAND B.V. ALL INTERNATIONAL RIGHTS RESERVED. AMP PRODUCTS MAY BE COVERED BY U.S. AND FOREIGN AND/OR PATENTS PENDING.		
-	-	-	-	-	-	-	THIS DRAWING IS UNPUBLISHED RELEASED FOR PUBLICATION		
-	-	-	-	-	-	-	AMP HOLLAND B.V. 's-Hertogenbosch, The Netherlands.		
-	-	-	-	-	-	-	NAME MODULAR JACK, 6 POS., BOTTOM ENTRY VERSION PACKAGING		
LTR.	REVISION RECORD	DR.	CHK.	DATE					
DR.:	E.v.EIJK	CHK.:	M. BRUMMANS	APP.:	R. SMEETS	DWG. No.	C-216446	REV. LTR.	SHEET
DATE:	19 DEC. '96	DATE:	-	DATE:	-			R	2 OF 2